

INSTALLATION NOTE:
 * SET SILL AND FLASHING ON FOAM WEATHER TAPE OR NON-SETTING CAULK.

CURB CONSTRUCTION AND MATERIALS (BY OTHERS)

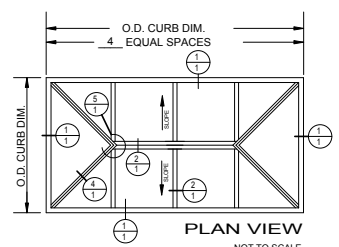
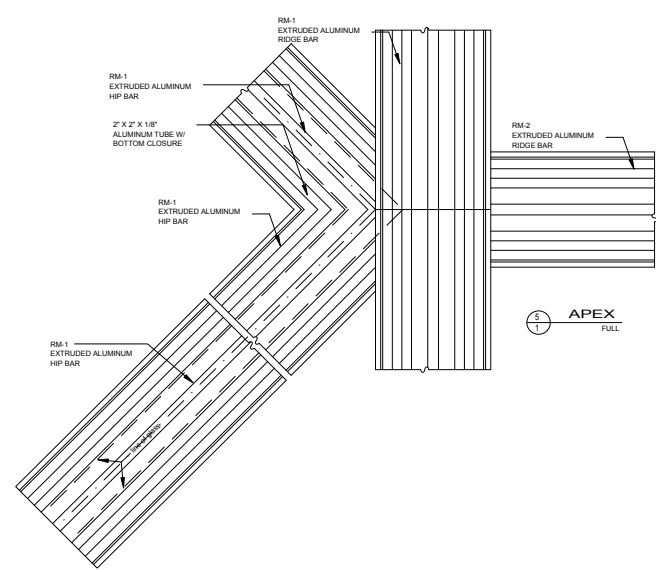
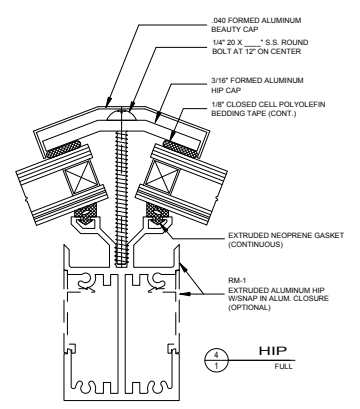
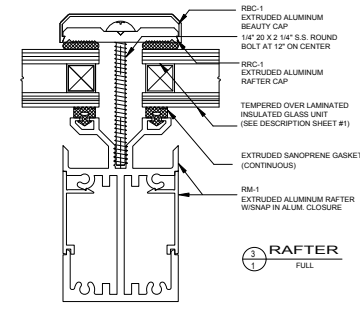

SKYLIGHT SCHEDULE							
UNIT	QTY.	TYPE	SLOPE	O.D. CURB DIM. (W X H)	M.D. DIMENSION (W X H)	# LITES	GLAZING:
		DOUBLE HIP				10	FINISH:
							SOLID:
							INSTALLATION:
							FIELD GLAZED: <input type="checkbox"/> SHOP GLAZED: <input type="checkbox"/>

	1055 TERMINAL WAY SAN CARLOS, CA 94070 PHONE: (925) 637-1440 FAX: (925) 637-9770	JOB No.:	PROJECT NAME:	SHEET No.:
		DRAWN BY: MEDPOINT DATE:	CONTRACTOR:	PHONE: